



Project \_\_\_\_\_  
 AIA # \_\_\_\_\_ SIS # \_\_\_\_\_  
 Item # \_\_\_\_\_ Quantity \_\_\_\_\_ C.S.I. Section 114000

## COMPACT SANDWICH PREP TABLES

with Raised Cover/Self-Contained  
 UPT 60" Wide Models



### STANDARD PRODUCT FEATURES

- High Quality Stainless Steel Exterior Top, Sides & Drawers
- Durable, Corrosion Resistant Anodized Aluminum Interior
- Provides NSF7 Performance, Even When Using 6" Deep Pans
- Standard Work Height 34 $\frac{3}{8}$ " on 4" casters
- Environmentally Friendly, Low GWP R-290 Refrigerant
- Top Cut-Outs Accommodate 1/6 Size Pans (divider bars and 4" deep plastic 1/6 size pans provided)
- Reinforced Pan Ledge (holds pans securely level)
- Removable Stainless Steel Insulated Pan Cover & Pivoting Lid
- Reversible, Full Length White Nylon Cutting Board
- Automatic Non-Electric Condensate Evaporator
- Full-Length Drawer Handle with Gasket Guard
- Magnetic Snap-In Drawer Gasket(s)
- Self-Closing Drawers with Stay Open Feature
- Electronic Control
- Interior Mounted Thermometer
- 8' Cord & Plug Attached
- Set of (6) 4" Casters



Intertek



This unit is listed to the applicable ETL and NSF Standards by an approved NRTL. Consult the factory or unit's data plate for approval information.

### AVAILABLE CONFIGURATIONS

#### 60" Wide Four Drawer Model

Model	Model Type
UPT6012-DD	60" Wide, 12 Pans on Top Rail / 9 Pans per Top Drawer / 6 Pans per Bottom Drawer
UPT6024-DD	60" Wide, 24 Pans on Top Rail / 9 Pans per Top Drawer / 6 Pans per Bottom Drawer

### ACCESSORIES & OPTIONS (\*field installed)

- CK21 (six 6" (15.2 cm) high casters for 60" models)
- CK25 (six 3 $\frac{1}{2}$ " (8.9 cm) high casters for 60" models)
- CK27 (six 2 $\frac{3}{4}$ " (6.9 cm) high casters for 60" models)
- LK6 (six 6" (15.24 cm) high legs for 60" models)
- Optional accessory kits shipped separately for field installation)

### FACTORY INSTALLED OPTIONS

- Stainless Steel Finished Back (model numbers will have '-SB' suffix)

Approved by \_\_\_\_\_ Date \_\_\_\_\_ Approved by \_\_\_\_\_ Date \_\_\_\_\_



# COMPACT SANDWICH PREP TABLES

with Raised Cover/Self-Contained  
UPT 60" Wide Models

MODEL:  
UPT6012-DD

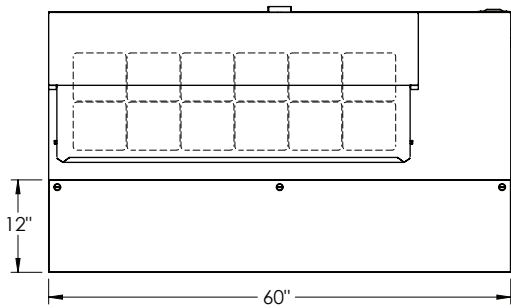

TOP VIEW

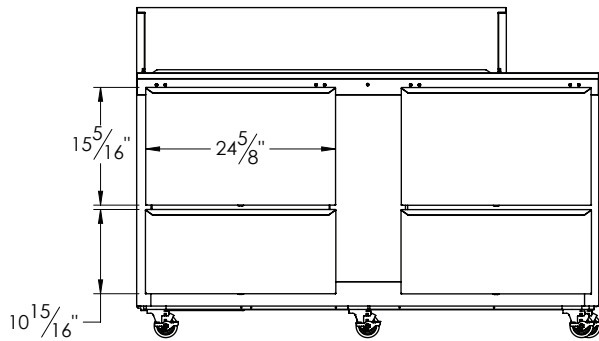

ELEVATION

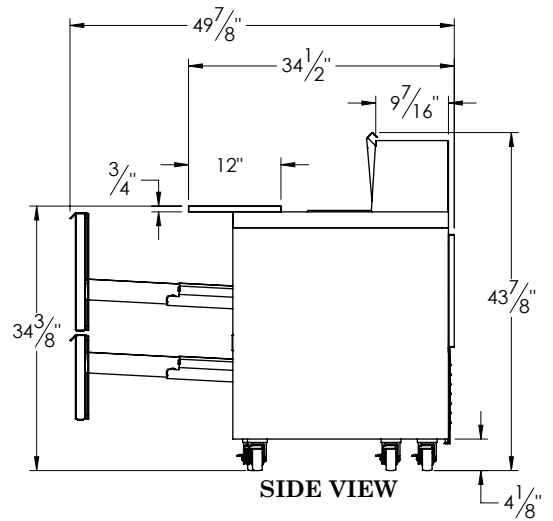

SIDE VIEW

CAD and/or Revit Files Available

<https://traulsen.klccad.com/>



# COMPACT SANDWICH PREP TABLES

with Raised Cover/Self-Contained  
UPT 60" Wide Models

## MODELS:

UPT6012-DD, UPT6024-DD

## EQUIPMENT SPECIFICATIONS

MODELS	UPT6012	UPT6024
<b>DIMENSIONAL DATA</b>		
Drawers per Cabinet	4	
# of 1/6 Size Pan Top	12	24
# of 1/6 Size Pans per drawer (top/bottom)	9/6	
# of 1/6 Size Pans per unit	42	54
Length - overall in.	60 (152.4 cm)	
Depth - overall in. <sup>1</sup>	34½ (87.6 cm)	
Depth - cutting board in.	12 (30.5 cm)	8 (20.3 cm)
Depth - drawer open in.	49⅞ (126.7 cm)	
Width drawer in.	24⅝ (62.5 cm)	
Height - overall on 4" casters	43⅞ (111.4 cm)	
Work Height on 4" casters	34⅜ (87.3 cm)	
<b>ELECTRICAL DATA (NEMA 5-15P attached)</b>		
Voltage	115/60/1	
Full Load Amperes	7.2	
<b>REFRIGERATION DATA</b>		
Refrigerant	R-290	
Refrigerant Charge oz.	5 (141.8 g)	
BTU/HR <sup>2</sup>   HP	1525   ¼ HP	
<b>SHIPPING DATA</b>		
Length - crated in.	69 (175.3 cm)	
Width - crated in.	42 (106.7 cm)	
Height - crated in.	56 (142.2 cm)	
Volume - crated cu. ft.	91 (2576.8 l)	
Weight - crated lbs.	408 (185.1 kg)	

### NOTES:

- Overall depth figure includes standard cutting board
- Compressor BTU based on a 90°F ambient and 20°F evaporator

When ordering please specify: Voltage, Hinging, and Options.

Equipped with one NEMA 5-15P Plug



### CONSTRUCTION, HARDWARE, INSULATION

Cabinet exterior front, one piece sides, pan lid, and drawers are constructed of heavy gauge stainless steel. Cabinet interior is constructed of anodized aluminum. The exterior cabinet back and bottom are constructed of galvanized steel.

The cabinet is insulated with an average of 2" thick high density, non-CFC, foamed in place polyurethane.

A ¾" thick, full-length, reversible white nylon cutting board is supplied standard.

### PANS & COVER

Each model is supplied standard with its full compliment of 4" deep plastic 1/6 size pans and stainless steel pan dividers. The insulated lift-up pan cover is constructed of stainless steel, and is easily removable for cleaning.

### REFRIGERATION SYSTEM

A balanced, rear mounted, front breathing, self-contained refrigeration system using environmentally-friendly, low GWP R290 refrigerant is provided. It features a capillary tube metering device, air-cooled hermetic compressor, a forced air evaporator coil and a non-electric condensate evaporator. An 8' cord and plug is provided. Standard operating temperature of the refrigerated base is 34 to 38°F (1.1° to 3.3°C).

### CONTROLLER

An electronic digital control is supplied standard. It includes a 3-Digit LED display, and a Fahrenheit or Celsius temperature scale display capability.

### DRAWERS

They are constructed using heavy gauge stainless steel drawer slides and 1¼" diameter stainless steel rollers. Gasket profile and material simplify cleaning and increase overall gasket life. Drawers include both a self-closing and stay-open feature.

### WARRANTY

Both a six year parts and labor warranty and a seven year compressor parts warranty (self-contained models only) are provided standard.